

300  
PSI

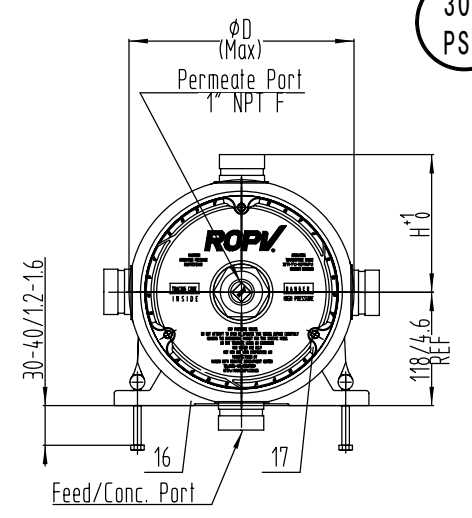
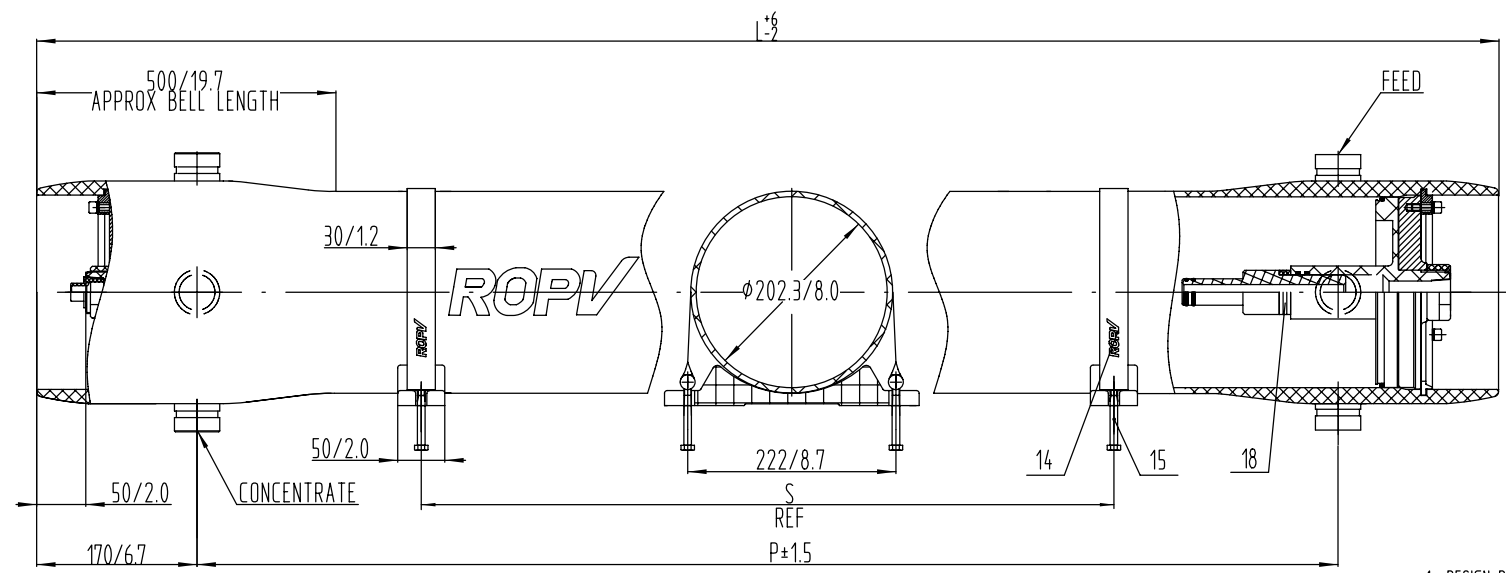

F/C PORT	D(MM/IN)	H(MM/IN)
1.5"(DN40)	244/9.6	148/5.8
2"(DN50)	248/9.7	148/5.8
2.5"(DN65)	258/10.1	153/6.0

- DESIGN PRESSURE 300PSI(2.1MPa).
- DESIGN TEMPERATURE 150°F(66°C).
- MIN ALLOWABLE TEMPERATURE 20°F(-7°C).
- WORKING MEDIUM, WATER pH RANGE 3-11.
- DIMENSIONS IN MM(INCHES) APPROX.
- INTERNAL PERMEATE PRESSURE NOT TO EXCEED 125PSI(0.88MPa).
- THE QUANTITY OF ITEM NO.8, 9 AND 10, DEPEND ON THE FEED/CONC. PORTS CONFIGURATION.
- ITEM 11 CONCENTRATE SIDE ONLY.
- ITEM 18 FEED SIDE ONLY.
- PLEASE OPERATE IN ACCORDANCE WITH USER MANUAL.
- FOR REFERENCE ONLY, NOT FOR CONSTRUCTION UNLESS CERTIFIED.
- SPARE PARTS FORM JUST FOR REFERENCE, SPECIFIC FORM OF THE SPARE PART DRAWING PREVAIL, SUBJECT TO CHANGE WITHOUT NOTICE.
- ALL PARTS CAN BE RECYCLED EXCEPT FRP SHELL.

18	A8023.1	Shim	0~3	Engineering Thermoplastic	
17	A8018.4	Locking Kit Segment Assy	6	304SS including Screw and Spring Pad	
16	A8016	Saddle	2~3	Rubber	
15	GB/T5782 M8x90	Strap Screw	4~6	304SS	
14	A8014.1	Strap	2~3	304SS-Brass and Rubber	
13	23.6x2.65G GB/T3452.1	O-ring	4	EPDM	
12	A8012.1	Adapler	2	Engineering Thermoplastic	
11	A8011.1	Thrust Ring	1	Engineering Thermoplastic	
10	S8030F(DZ) S8030E(DZ) S8045D(DZ)	2.5"Feed/Conc. Port 2"Feed/Conc. Port 1.5"Feed/Conc. Port	2~4	316LSS	OPT
09	A8009.1-3	Retaining Ring	2-4	304SS	
08	69(65)x3.55G GB/T3452.1 54.5x2.65G GB/T3452.1 42.5x2.65G GB/T3452.1	O-ring	4~8	EPDM	
07	A8007	Permeate Port Locknut	2	Engineering Thermoplastic	
06	A8006	Plug	1	Engineering Thermoplastic	
05	36.5x3.55G GB/T3452.1	O-ring	4	EPDM	
04	190x5.3G GB/T3452.1	O-ring	2	EPDM	
03	A8003.4	Sealing Plate	2	Engineering Thermoplastic, 304SS ring	
02	A8002.3 A8002.2	Bearing Plate	2	Aluminium Alloy-Hard anodized	ASME
01	S8012.1-8	Pressure Shell	1	FRP	
REF	PART NUMBER	DESCRIPTION	QTY	MATERIAL	NOTE

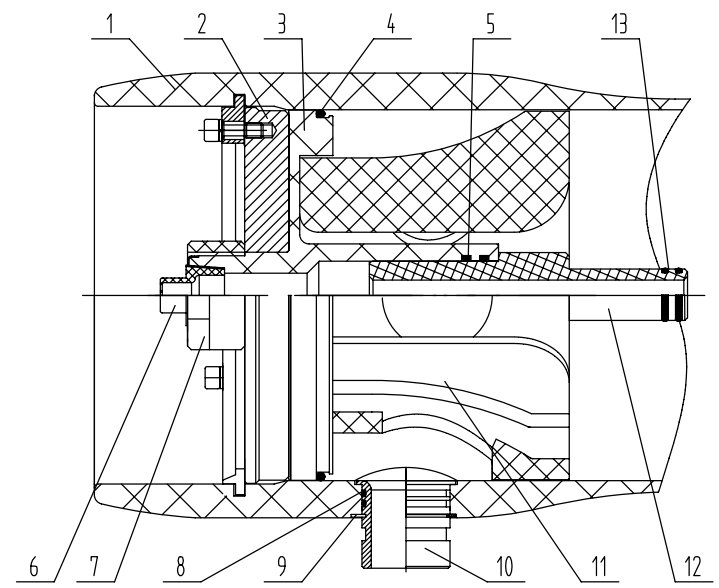

Shell length code	Shell number	L L.O.A MM/IN	P Port to port MM/IN	S Span MM/IN	Approx assembly weight (1.5"Feed/Conc. Port) KG/LB
1	S8012.1	1534/60.4	1194/47	500/19.7	32/71
2	S8012.2	2550/100.4	2210/87	1455/57.3	39/86
3	S8012.3	3566/140.4	3226/127	2064/81.3	46/101
4	S8012.4	4582/180.4	4242/167	1600/63x2	53/117
5	S8012.5	5598/220.4	5258/207	2000/78.7x2	60/132
6	S8012.6	6614/260.4	6274/247	2358/92.8x2	67/148
7	S8012.7	7630/300.4	7290/287	2865/112.8x2	74/163
8	S8012.8	8646/340.4	8306/327	3373/132.8x2	81/179

**ROPV** DESIGN **Harbin ROPV Industry Development Center**

REVIEW MODEL R8040B300S PRESSURE VESSEL

APPROVAL DRG R8040B300S-00 REV 10.2.3