

Quantity decided by customer
Non-adjacent 90°

24	A8023.1	Shim	0-3	Engineering Thermoplastic	
23	82.5x3.55G GB/T3452.1	O-ring	4-8	EPDM	
22	A8022.3	Permeate Port	2	Engineering Thermoplastic. 316LSS Ring	
21	47.5x3.55G GB/T3452.1	O-ring	2	EPDM	
20	58x2.65G GB/T3452.1	O-ring	2	EPDM	
19	A8020	Securing Ring	2	Engineering Thermoplastic	
18	A8018.2	Locking Kit Segment	2 Set	316SS	
17	GB/T70.1 M8x20	Securing Ring Screw	6	316SS	
16	A8016	Saddle	2-3	Rubber	
15	GB/T5782 M8x90	Strap Screw	4-6	316SS	
14	A8014.3	Strap	2-3	316SS-Brass and Rubber	
13	23.6x2.65G GB/T3452.1	O-ring	4	EPDM	
12	A8012.6	Adapter	2	Engineering Thermoplastic	
11	A8011.1	Thrust Ring	1	Engineering Thermoplastic	
10	S80120G(DZ)	3"Feed/Conc. Port	2-4	Super Duplex Stainless Steel	
09	A8009.4	Retaining Ring	2-4	316SS	
08	97.5x3.55G GB/T3452.1	O-ring	2-4	EPDM	
07	A8007	Permeate Port Locknut	2	Engineering Thermoplastic	
06	A8006	Plug	1	Engineering Thermoplastic	
05	36.5x3.55G GB/T3452.1	O-ring	4	EPDM	
04	190x5.3G GB/T3452.1	O-ring	2	EPDM	
03	A8003.3	Seating Plate	2	Engineering Thermoplastic	
02	A8002.10	Bearing Plate	2	Aluminium Alloy-Hard anodized	
01	S8006.9-16	Pressure Shell	1	FRP-316SS Embedded ring wound in place	
REF.	PART NUMBER	DESCRIPTION	QTY.	MATERIAL	NOTE

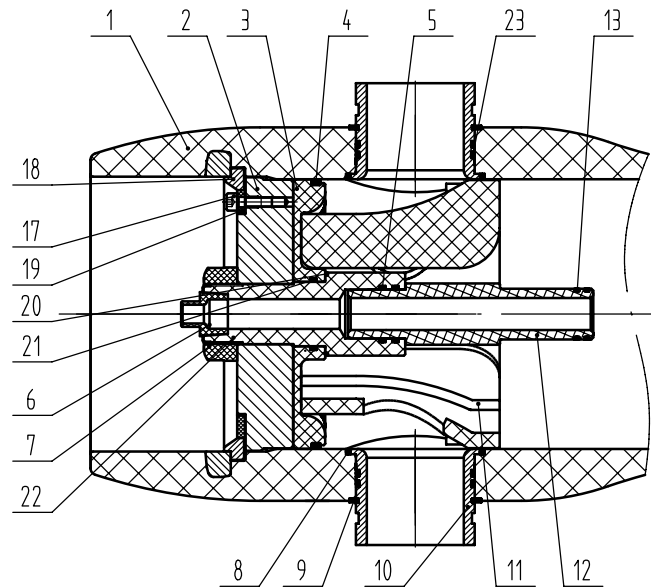

- DESIGN PRESSURE 1200PSI(8.3MPa).
- DESIGN TEMPERATURE 150°F(66°C).
- MIN ALLOWABLE TEMPERATURE 20°F(-7°C).
- WORKING MEDIUM,SEA WATER OR BRACKISHWATER,pH RANGE 3-11.
- DIMENSIONS IN MM(INCHES APPROX).
- INTERNAL PERMEATE PRESSURE NOT TO EXCEED 125PSI(0.88MPa).
- THE QUANTITY OF ITEM NO.8 9 10 AND 23,DEPEND ON THE FEED/CONC. PORTS CONFIGURATION.
- ITEM 11 CONCENTRATE SIDE ONLY.
- ITEM 24 FEED SIDE ONLY.
- PLEASE OPERATE IN ACCORDANCE WITH USER MANUAL.
- FOR REFERENCE ONLY,NOT FOR CONSTRUCTION UNLESS CERTIFIED.
- SPARE PARTS FORM JUST FOR REFERENCE,SPECIFIC FORM OF THE SPARE PART DRAWING PREVAIL,SUBJECT TO CHANGE WITHOUT NOTICE.
- ALL PARTS CAN BE RECYCLED EXCEPT FRP SHELL.

Shell length code	Shell number	L L O A MM/IN	P Port to port MM/IN	S Span MM/IN	Approx assembly weight (3"Feed/Conc. Port) KG/LB
1	S8006.9	1620/63.8	1143/45	320/12.6	114/251
2	S8006.10	2636/103.8	2159/85	1336/52.6	136/300
3	S8006.11	3652/143.8	3175/125	2064/81.3	158/348
4	S8006.12	4668/183.8	4191/165	1600/63x2	180/396
5	S8006.13	5684/223.8	5207/205	2000/78.7x2	202/445
6	S8006.14	6700/263.8	6223/245	2358/92.8x2	224/493
7	S8006.15	7716/303.8	7239/285	2865/112.8x2	246/542
8	S8006.16	8732/343.8	8255/325	3373/132.8x2	268/590

ROPV

DESIGN: Harbin ROPV Industry Development Center

REVIEW: MODEL R8040B1200S (Large Opening) PRESSURE VESSEL

APPROVAL: DRG R8040B1200S-00(3") REV 10.2.3